



WATER MOTOR ALARM GONG MODEL: SFL-WMAG



GENERAL DESCRIPTION

Sanflo Sprinkler Alarm is a hydraulically driven mechanical bell. It does sound a continuous alarm when the sprinkler system operates. The impeller and drive shaft are energy efficient, made from light weight nonmetallic material and do not require any external lubrication. The gong, protection cover and motorhousing are made of corrosion resistant aluminium alloy.

Sprinkler Alarm with mounting Type-B is wall mounting type. Type-B is suitable for 50 to 250 mm thick wall and curves with 325 mm long drive shaft as standard supply. For wall thickness 250 to 450 mm or longer a special extension drive shaft can be supplied on request.

OPERATION

When the sprinkler system is activated by fusing of one or more automatic sprinklers at fire condition, the water flows through the Alarm Valve/Deluge Valve and enters the sprinkler alarm through the nozzle, creating a high velocity jet which strikes the impeller causing the drive shaft and the striker arm assembly to rotate. The alarm arm assembly rotates and strikes to impact against the aluminium gong, producing a continuous alarm. The waste water then drains out through a 25NB drain outlet.

KEY TECHNICAL FEATURES

Mounting type: Type-A & Type-B	GONG Depth: 50mm (2")
Water working pressure: 17.5 Bar (250 PSI)	Finish: Red RAL 3001
Connection: Inlet : 3/4" BSPT (3/4" NPT) Drain : 1" BSPT (1" NPT)	Weight (Approx) 3.0 Kg / 6.6 Lbs
GONG Diameter: 205mm (8")	Ordering information: Mounting type



WATER MOTOR ALARM GONG MODEL: SFL-WMAG

DESIGN REQUIREMENT

Strainer is required in the Sprinkler Alarm line to protect the 3.2 mm nozzle in the water motor housing from clogging.

The alarm line pipe must be 20NB (3/4") size with 22.8 mtrs. (75 feet) maximum total length of pipe with minimum number of fittings. If the length of the pipe exceeds 22.8 mtrs. (75 feet), then higher size pipe must be used to reduce hydraulic friction loss.

The Sprinkler Alarm should not be located more than 1.8 mtrs. (Six feet) above Alarm Valve / Deluge Valve.

One Sprinkler Alarm may be connected to one or maximum of three alarm lines of separate fire systems. For interconnecting more than one Sprinkler Alarm, a swing check valve in each line need to be provided.

MAINTENANCE

Qualified and trained person must commission the system. After few initial successful tests an authorised person must be trained to perform inspection and testing of the system.

Even though corrosion resistant material is used in the construction of the Sprinkler Alarm, it is suggested that the Sprinkler Alarm be examined and tested at regular intervals to ensure that the nozzle is free from obstruction and the impeller is free to rotate. The inspection should include the following, in addition to any specific requirement of NFPA, or as required by authority having jurisdiction.

1. Clean the 20 NB (3/4") Strainer provided in the alarm line.
2. Open the 3/8" plug provided on the inlet of the Sprinkler Alarm and clean out any accumulated particles.
3. Detach the Gong, clean the internal surface and refit in proper sequence.
4. Activate the Sprinkler Alarm to verify clear and steady sound.

SPRINKLER ALARM MOUNTING TYPE - A

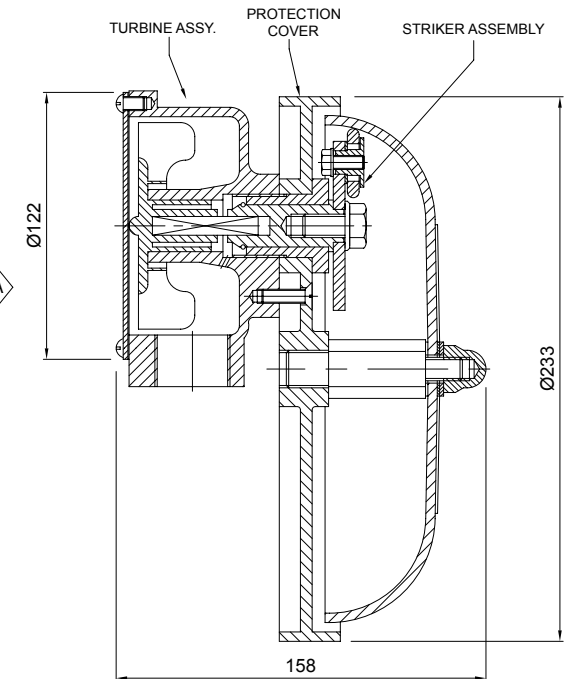
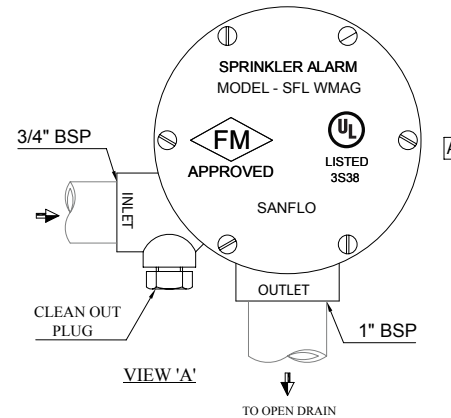

INSTALLATION OF SPRINKLER ALARM MODEL SFL-WMAG MOUNTING TYPE - A

The Sprinkler Alarm with mounting Type-A is supplied pre-assembled. Connect the Alarm port of the Alarm valve or Deluge valve to the inlet of the sprinkler alarm assembly with 20NB (3/4") pipe with proper support. A 20NB (3/4") strainer is to be provided as close as possible to the Sprinkler Alarm assembly. Connect the 25NB (1") drain pipe to the housing, taking due care that the drain discharge is running to a safe location and keep the drain free from obstruction. A blocked drain discharge may create back pressure and prevent the Sprinkler Alarm from operating properly.

The 20NB (3/4") inlet and 25NB (1") drain pipe should be properly supported with the help of the bracket, so that in turn proper support is available for the Sprinkler Alarm. The inlet and the drain pipe is to be preferably connected with an union for easy removal and re-fixing of the Sprinkler Alarm during maintenance.

The Sprinkler Alarm must be installed in accordance with the requirement of NFPA, TAC or to the requirement of the local authority having jurisdiction.



WATER MOTOR ALARM GONG

MODEL: SFL-WMAG

INSTALLATION OF SPRINKLER ALARM MODEL SFL-WMAG MOUNTING TYPE - B

1. Locate and cut a hole through the building wall to accommodate a 20NB (3/4") pipe with coupling (galvanised pipe to be supplied by the installer). The required length of support pipe is equal to the thickness of the wall minus 30 millimetres. The pipe is to be threaded with standard 20NB (3/4") pipe threading on both the ends to a length of 20 millimetres. Cut the drive shaft length, equal to the wall thickness plus 43 millimetres.
2. Insert one end of the drive shaft into the square hole provided in the impeller of the Sprinkler Alarm gong assembly. One end of 20NB (3/4") support pipe is to be screwed to the coupling provided with the assembly and the other end of the pipe is to be screwed to the housing of the Sprinkler Alarm motor assembly as shown in the figure. Position this assembly against the building wall through a washer with the support pipe extending through the wall.
3. Connect the alarm port of the Alarm Valve or Deluge Valve to the inlet of the Sprinkler Alarm assembly with 20NB (3/4") pipe, with proper support. A 20NB (3/4") strainer is to be provided as close as possible to the Sprinkler Alarm assembly.
4. Move to the other side of the wall, place protection cover on to the pipe coupling (screwed to the pipe) and hold against the wall. Insert the bush (assembly with drive shaft adaptor) into the hole provided in the protection cover and thereby hand tighten the coupling extending through the wall. Make sure that the drive shaft is properly fitted in the square hole of impeller and drive shaft adaptor. This can be ensured by rotating the drive shaft adaptor. The drive shaft adaptor should rotate without any binding while tightening the bush. If any binding is noticed then unscrew the bush and refit. After ensuring that the drive shaft is properly placed in the square holes at both ends, wrench tight the bush.
5. Place the gong over the gong post with washers as shown in the cross-sectional drawing and hand tighten the dome nut, rotate the gong until the lettering is properly originated. Wrench tighten the dome nut.
6. Connect the 25NB (1") open drain pipe to the motor housing, taking due care that the drain discharge is running to a safe location and keep it free from obstruction.

SPRINKLER ALARM MOUNTING TYPE - A

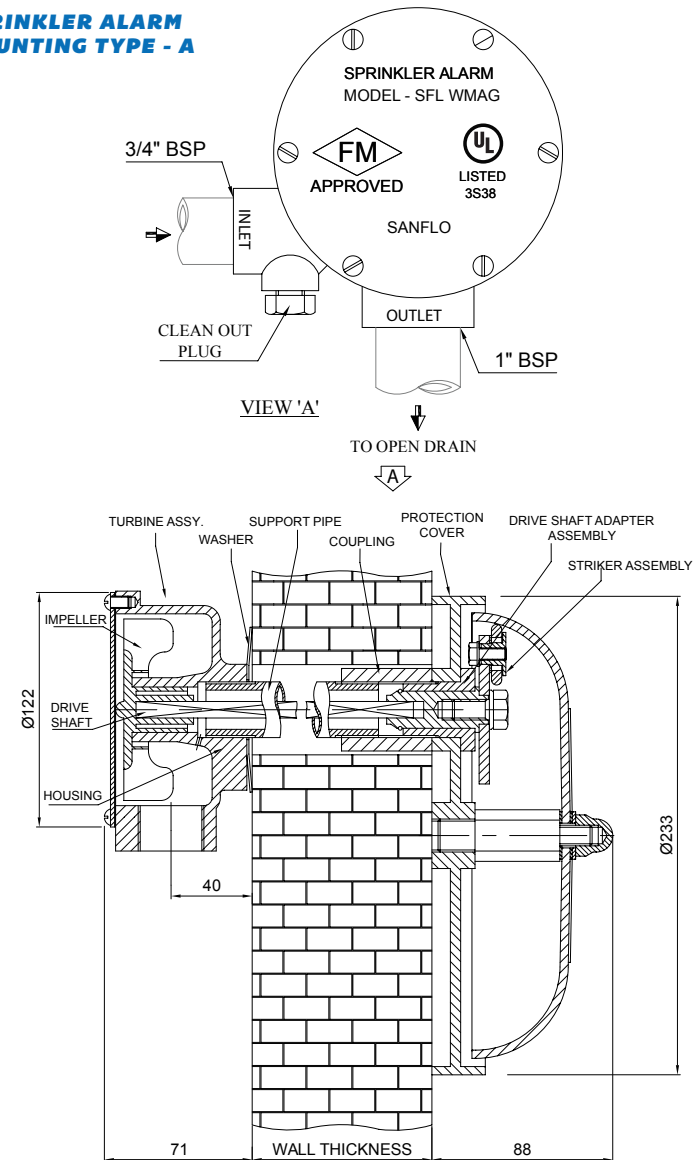

NOTE: ALL DIMENSIONS IN MM UNLESS OTHERWISE SPECIFIED